



## HOW TO SELECT A FLOOR DRAIN

Floor and area drains receive liquid from surrounding areas and by the attached piping, convey the liquid to the storm or sanitary drainage system. Floor drains are primarily used for inside locations where the flow rate into the drain can be anticipated. Area drains are designated for outside areas where rainfall intensity dictates sizing. Drains should be selected with sufficient top size and grate free area to pass the anticipated flow. Grate free area is defined as "the total area of the drainage openings in the grate." The drain outlet should be sized large enough so that it will safely pass the maximum flow through the grate, without creating water buildup.

**Sizing and Location**—For most indoor locations, the grate free area should be 1.5 times the transverse area of the connecting pipe. The number and location of drains are based on the configuration of the floor plan, type of operation and location of equipment. Location and number of floor drains required can be determined only after careful review of the plans and anticipated building use.

Floor drains or area drains, when used to drain exterior areas, should have an open area equal to twice the transverse area of the connecting pipe (Table 1.) See roof drain section for rainfall and sizing data

**TABLE 1**  
**Recommended Grate Free Areas for Various Outlet Pipe Sizes**

Nominal Pipe Size	Transverse Area of Pipe (SQ.IN.)	Minimum Flow Requirements (Interior Areas) (SQ.IN.)	Minimum Flow Requirements (Exterior Areas) (SQ.IN.)
1 ½"	2.04	3.06	4.08
2"	3.14	4.71	6.28
3"	7.06	10.59	14.12
4"	12.60	18.90	25.20
5"	19.60	29.40	39.20
6"	28.30	42.45	56.60
8"	50.25	75.38	100.50

## SELECTING THE DRAIN



After the top size is determined based on anticipated flow into the drain, the following points should be considered when making the final selection of the floor drain.

**(Typical Water Sources and GPM Demand)**

- ▶ Aspirator – 2.5
- ▶ Ball Cock (Water Closet) – 3.0
- ▶ Bath Faucet – 5.0
- ▶ Dishwashing Machine – 4.0
- ▶ Drinking Fountain - .75
- ▶ Hose Bib – 5.0
- ▶ Laundry Faucet – 5.0
- ▶ Laundry Machine – 5.0
- ▶ Shower Head – 5.0
- ▶ Flush Valve – 15.0-35.0
- ▶ Sink Faucet – 5.0

**Selection of Top (Based on Anticipated Traffic)**

Establish the maximum anticipated traffic (loading) which will pass over the grate and select the grate type which will support that load. Each drain shown in this section has a description listing the type of load it will take. The categories listed are for various drains in respect to grate loading. The load classifications are in accordance with the American National Standards ASME A112.6.1M. ASME Ratings are as follows:

Load Classification ASME A112.6.1M	Safe Live Load
Light Duty	Under 2,000 LB
Medium Duty	2,000 - 4,999 Lb
Heavy Duty	5,000 – 7,499 Lb
Extra Heavy Duty	7,500 – 10,000 Lb
Special Duty	Over 10,000 Lb

The above categories are given as a guide only. Conditions of use, load concentrations, installations, etc., can affect results and service. For unusual applications, consult the factory. After the weight loading capacity is established, a suitable drain can be selected. Illustrated below are various types of grate designs which will be mentioned throughout the catalog.

Load Class DIN 19580	Safe Live Load (Lbs)	Application
A	3,372	Light Pedestrian Traffic
B	28,100	Sidewalks & Private Parking Areas
C	56,200	Parking Areas and General Commercial
D	89,920	Roads and Highways
E	134,800	Industrial Areas & Light Commercial
F	202,320	Aircraft Facilities and Heavy Industrial

**An open area / flow rate calculator is available from Wade upon request:**

Wade Specification Drainage Products  
11910 CR 492 • Tyler, TX 75706



Below illustration is a typical application using the calculator.

## DRAIN OPEN AREA / FLOW RATE CALCULATIONS

ASSUMED VALUES / UNITS USED IN SPREADSHEET CALCULATION:

- Q = FLOW RATE (GALLONS PER MINUTE)
- Cd = DISCHARGE COEFFICIENT (0.6 ASSUMED)
- A = OPEN AREA OF GRATE (SQUARE INCHES)
- g = ACCELERATION (32 ft/sec/sec)
- h = HEAD ABOVE FLOOR (INCHES)

\*NOTE: ORIGINAL FORMULAS SHOWN AND UNITS USED ARE FOR REFERENCE ONLY.  
SPREADSHEET CALCULATES USING INCH AND SQUARE INCH UNITS FOR CONVENIENCE

INDICATES FORMULA INPUT VALUE CELL

INDICATES FORMULA OUTPUT VALUE CELL

### OPEN AREA CALCULATION

\*FORMULA USED:

(GIVEN FLOW RATE & HEAD ABOVE FLOOR)

$$A = Q / (448.2 \times Cd \times \sqrt{2gh})$$

ENTER FLOW RATE (GPM): 10.00 A (SQUARE FEET)

ENTER HEAD ABOVE FLOOR (INCHES): 0.25 h (FEET)

OPEN AREA (SQUARE INCHES): 4.62

### FLOW RATE CALCULATION

\*FORMULA USED:

(GIVEN OPEN AREA & HEAD ABOVE FLOOR)

$$Q = 448.2 \times Cd \times A \times \sqrt{2gh}$$

ENTER OPEN AREA (SQUARE INCHES): 4.62 A (SQUARE FEET)

ENTER HEAD ABOVE FLOOR (INCHES): 0.25 h (FEET)

FLOW RATE (GPM): 9.99

After the weight loading capacity is established, a suitable drain can be selected. Illustrated below are various types of grate designs which will be mentioned throughout the catalog.

### Selection of Top Material (Unfinished Areas)



Drains located in heavy traffic areas should be specified with heavy duty ductile iron grates. In areas where shock loads are anticipated, a ductile iron grate is more desirable in lieu of cast iron. Cast ductile iron is acceptable for most unfinished areas such as warehouses, loading docks, boiler rooms and similar areas.

**(Finished Areas)**

Most drains are available with nickel bronze, bronze or stainless steel tops to match the surrounding trim in finished areas. Usually finished areas require light duty or medium duty tops.

**(Finished Areas with Increased Load)**

Many finished floor areas are subject to increased loadings. Examples are convention centers, equipment showrooms and industrial plants. Heavy duty cast iron tractor grates can be specified with bronze or nickel bronze veneered tops.

**Top Shape**—Round, square or rectangular styles are available to blend with all types of construction and floor patterns. The round top is the most flexible type since it can be easily oriented to most floor patterns.

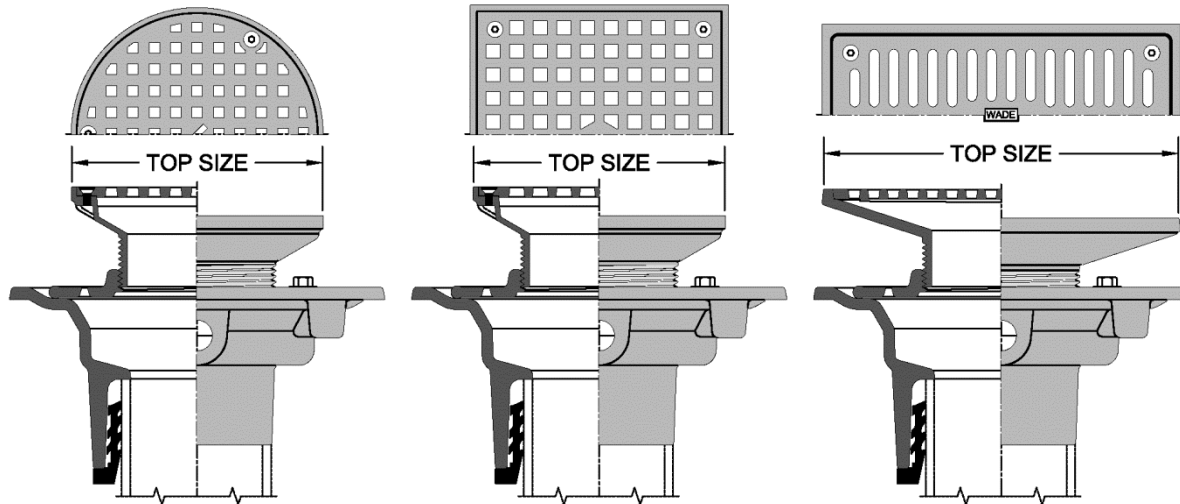

In areas subject to vehicular traffic, non-tilt tractor style grates are preferred. The tractor grate incorporates a skirt extending down on the perimeter of the grate. The deep skirt or lugs on the grate catch the side of the drain body when a vehicle rolls over and keeps it in position. In parking garages which see vehicular traffic as well as pedestrian traffic, a combination heel proof / tractor grate is available. Heel Proof incorporates narrower slots or holes – normally  $\frac{1}{4}$ " .

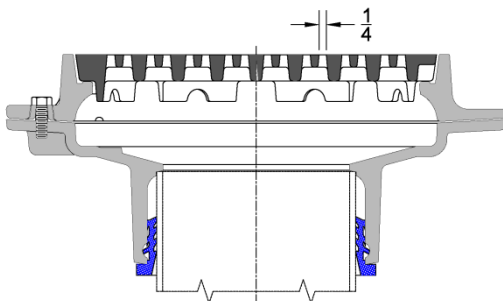

Some areas are subject to petty mischief and vandalism. Drains with unsecured grates are easy targets. Grates can be secured with vandal proof fasteners. Wade normally provides hex key (Allen



Head) fasteners for vandal proofing. For higher security, pin allen, pin torx or spanner style screws are available.

Flat top grates in gymnasium shower areas likely to become clogged with towels or wash cloths and result in flooding. A dome grate located in the corner of the shower or an angle grate against the floor and wall intersection will prevent clogs.

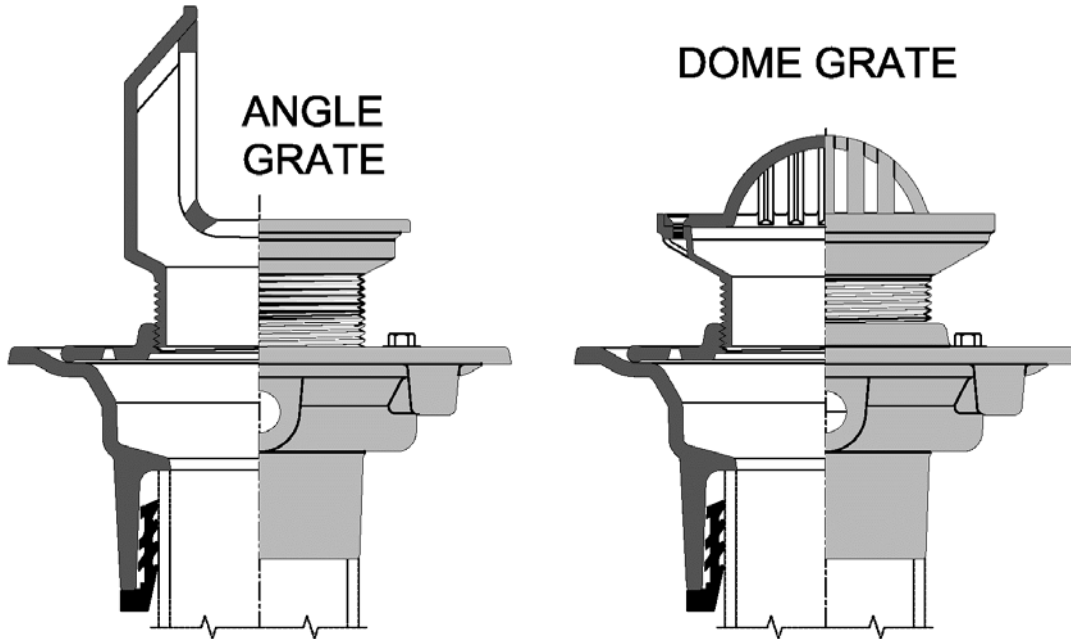

**Body Selection**—Body depth is proportioned to the top size. Many Wade floor drains can be specified with various body depths. A deeper body is desirable when unusually large amounts of water are to be drained or an extra-large sediment bucket is required.

Most floor drain bodies are available with a flange for either anchoring the drain in the floor slab or for use as a flashing flange in upper floors and waterproofed areas. Many Wade drains are regularly furnished with a flanged body and a combination top with integral flashing collar which can be used to clamp the waterproof membrane.

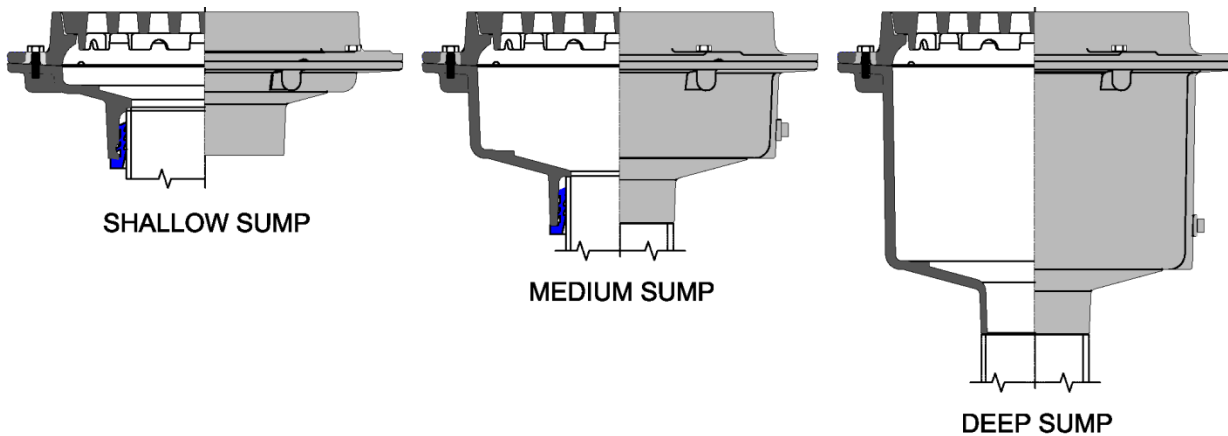



The Suffix "E" designates a wide flange that can be furnished on certain Wade floor drains. This flange receives the membranes and coatings of a waterproof floor covering system. These coverings are thin coatings which are installed in a series of trowel coats. The covering forms its own membrane, flashing and durable traffic surface. The wide flange is regularly furnished 4" wide. The usual covering is approximately 3/16" thick and may be applied over many subsurface such as concrete, gypsum or wood decks. This type of covering is particularly adaptable to flat roofs which are used for recreational purposes, balconies, area ways, plazas, sun decks, floors and corridors.

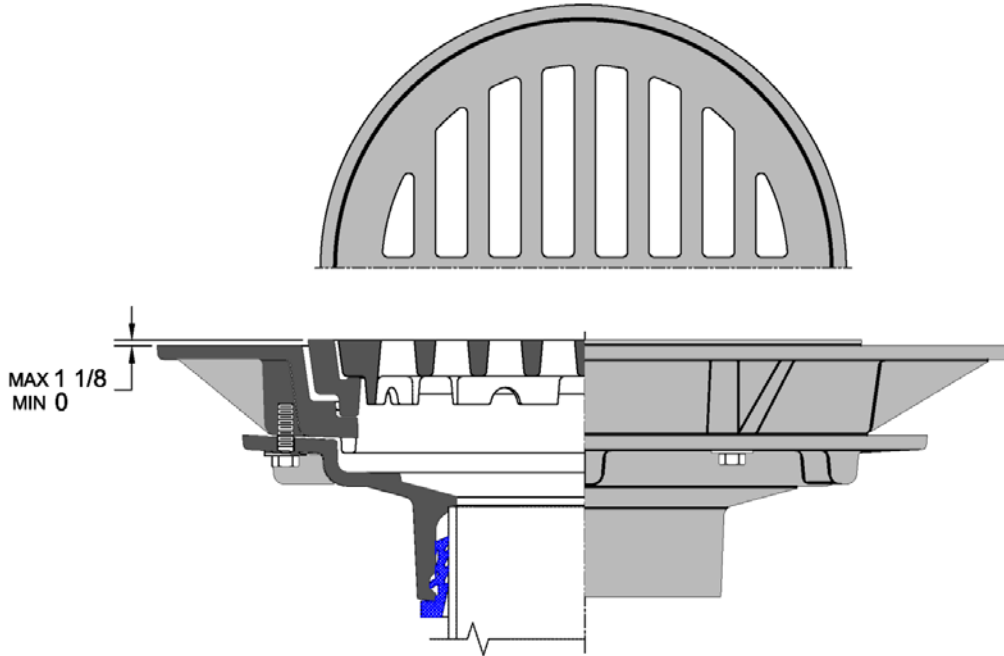

When a "E" flange is required on drains other than those shown in the catalog, the Suffix "E" must be used with the model number. The flange will be 4" wide (minimum) with a 3/16" lip regularly furnished. If the waterproof deck covering is greater or less than 3/16", the lip dimension must be specified or the drain has to be set at the proper elevation by the plumbing contractor to compensate for these differences.

Roughing dimensions of the body must be adjusted accordingly. The drain body should be set low enough to permit "dimpling" of the area surrounding the drain.



## Bucket Variations

Some job applications require drains with buckets to intercept and collect debris such as solid objects and leaves so the waste system is protected. Wade has various types of buckets for different applications to accomplish this purpose.

**NOTE:** Where a bucket is not available, a dome bottom strainer or flat bottom strainer may be used to protect the waste system.

### SOLID SUSPENDED BUCKET WITH PORTED OPENINGS

This bucket is ideal for drains which are located in areas where large amount of debris are anticipated. It is particularly useful in areas such as vegetable storerooms where vegetables are pre-cleaned and a considerable amount of leaves and stalks are washed into the drain. The solid bottom of this bucket retains this type of solid matter while the overflow is discharged through the screens in the top of the bucket. Small diameter holes in the bottom allow the bucket to weep, thus increasing capacity.

### DEEP SUSPENDED SLOTTED BUCKET

Used where large leafy objects such as peelings, leaves and paper are to be intercepted. When wetted down, these types of solids will compact at the bottom of the bucket. Slots run completely up the sides of the bucket to offer complete drainage even when the bottom section is filled with debris.

### SOLID FREE STANDING BUCKET

Used where heavy materials such as sand, stones and chips are to be intercepted and separated from the drainage water. When sand laden drainage water enters the bucket, the sand falls to the bottom and the clear water flows over the top of the bucket into the waste line.

### GRATE SUPPORTED BUCKET

The sediment essentially replaces the standard grate and a smaller grate rests inside the bucket. This insures the sediment bucket will be re-installed after cleaning.

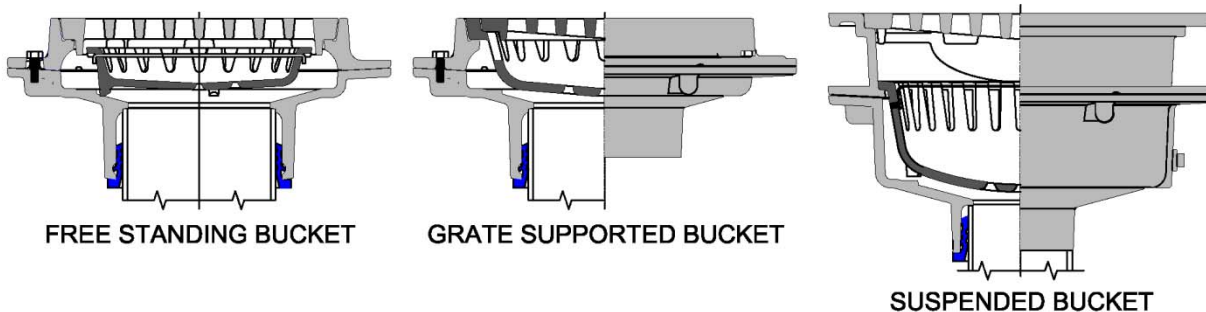



## **Connections**

The means by which a drain becomes an integral part of the drainage system should be considered so that proper outlets compatible to the connected piping material are used. There are several basic outlet connections to consider and each is dependent upon the piping material, contractor preference and occasionally, the plumbing code requirements. Wade offers several basic connection types as well as various special connections as required.

### **Ty-Seal (Push-On)**

Wade Ty-Seal gaskets are available for use with cast iron, plastic, steel or glass pipe. Installation of your floor drains using Ty-Seal Push-On can represent a significant reduction in time and labor costs over conventional caulk or NO-HUB installations.

Ty-Seal Push-On drains are available with most bottom outlet models by specifying (TY) and piping material used. Ty-Seal outlets accommodate cast iron SV or No-Hub Pipe as well as Schedule 40 steel and PVC Pipe in 2", 3" and 4" sizes. If 6" Schedule 40 steel or PVC is specified, a special gasket, suffix (TX) is required. The Ty-Seal joint consists of a hub outlet body and a factory inserted neoprene gasket. The installer simply lubricates the plain end of the spigot and the inside of the gasket, then pushes the drain body down over the pipe until contact is made with the internal stop of the drain body hub. The installation eliminates the need for hot lead, caulking irons, NO-HUB clamps, etc.

### **NO-HUB (Hubless)**

The drain outlet is a shortened spigot for direct connection to hubless soil pipe of size and dimension conforming to CISPI specification 301. This connection uses the very popular No-Hub coupling consisting of a neoprene sealing sleeve surrounded by a corrugated stainless steel shield with multiple band clamps.

### **Inside Caulk**

One of the oldest connection methods available, inside caulk relies on lead and oakum to seal. The pipe inserts into a hub on the bottom of the drain body with the annular space between the body and pipe allowing the "caulking" from above. Care must be taken to insure the pipe outside diameter is compatible to the caulk hub. Inside caulk may be used for a variety of pipe materials and sizes but is specifically designed for cast iron hubless or hub and spigot soil pipe.

### **CAULK SUPPORT STRAPS (By Others)**

A caulk support strap eliminates the need for supports for the drain during the caulking operation. Its unique design allows it to be used on 2, 3 or 4" service weight or extra heavy pipe. The installer secures the strap in place, then rests the inside caulk outlet drain on the caulk support strap. The strap supports the drain body weight and the force created by the caulking operation without slipping.

To eliminate the higher cost and environmentally evasive effects of lead and oakum, donut gaskets are available from various sources. The inside surface of the gasket is lubricated, pressed in place down over the pipe and lightly tapped until flush with the top of the pipe. Installation is fast and simple and the caulk support strap may be left in place or reused.

### **THREADED**

A female NPT threaded connection is available on many Wade drain bodies and accommodates many IPS piping materials including steel, stainless steel, plastic and cast iron. It will also accept male threaded adapters.

## **OUTLET TYPES**



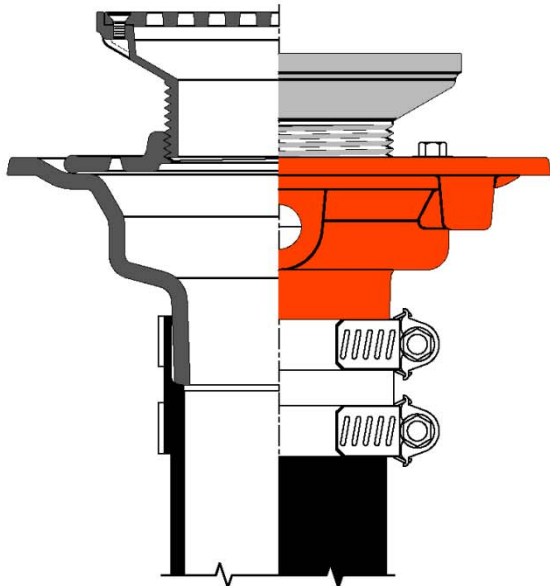

**NO-HUB**

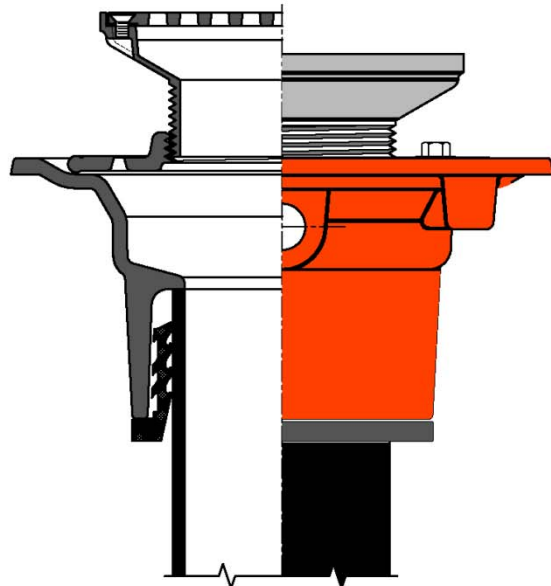

**TY-SEAL**

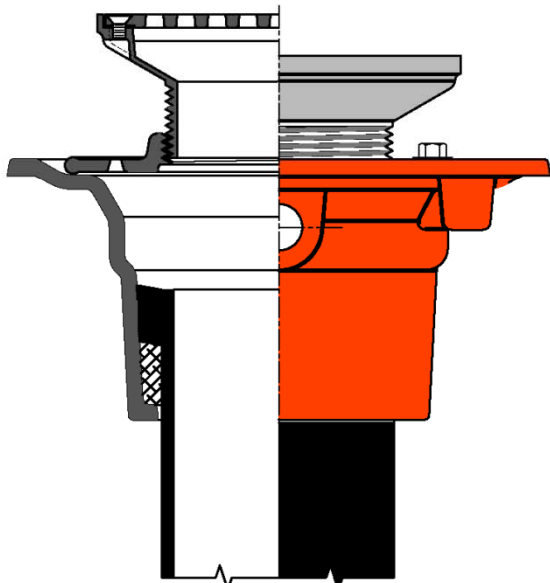

**INSIDE CAULK**

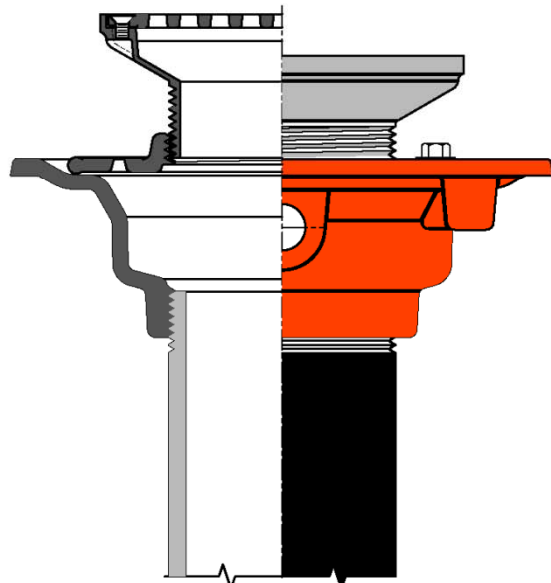

**THREADED**



## BACKFLOW PREVENTION

Blockages in the waste piping system will cause a back-up of drainage. The back-up will escape at the lowest accessible opening. Floor drains are a prime location. The only practical remedy is to provide backflow protection at these locations. Protection against backflow from sewers is essential in basements and other areas located below the curb or ground elevation where gravity drainage to the sewer main is planned. Drains with backflow prevention should also be considered above the main sewer such as second floor toilet rooms when an obstruction below will cause buildup from floors above. Wade offers several basic types as well as various special versions as required.

## SWING CHECK ASSEMBLIES

Usually incorporated into drains with integral p-traps, this type has a body mounted either vertical or horizontal with a flapper that pivots as water flows. Backflow forces the disc against a seat on the body.

## BALL FLOAT ASSEMBLIES

Incorporated into the vertical outlet, a hollow ball is suspended below the seat. The Water flowing through the drain passes around the ball and into the piping. At the moment of backflow, the ball floats up until it contacts the seat.

## CENTER GUIDED FLOAT CHECK ASSEMBLIES

Similar to a ball float assembly, this unit can be installed in existing drains quickly and easily. A compression seal between two plates forces against the side walls of a strainer shank or inside of the vertical piping. The center post attached to a float and guided through the top plate keeps the float centered and keeps it from being washed downstream. The bottom plate acts as a seat in the event of backflow.

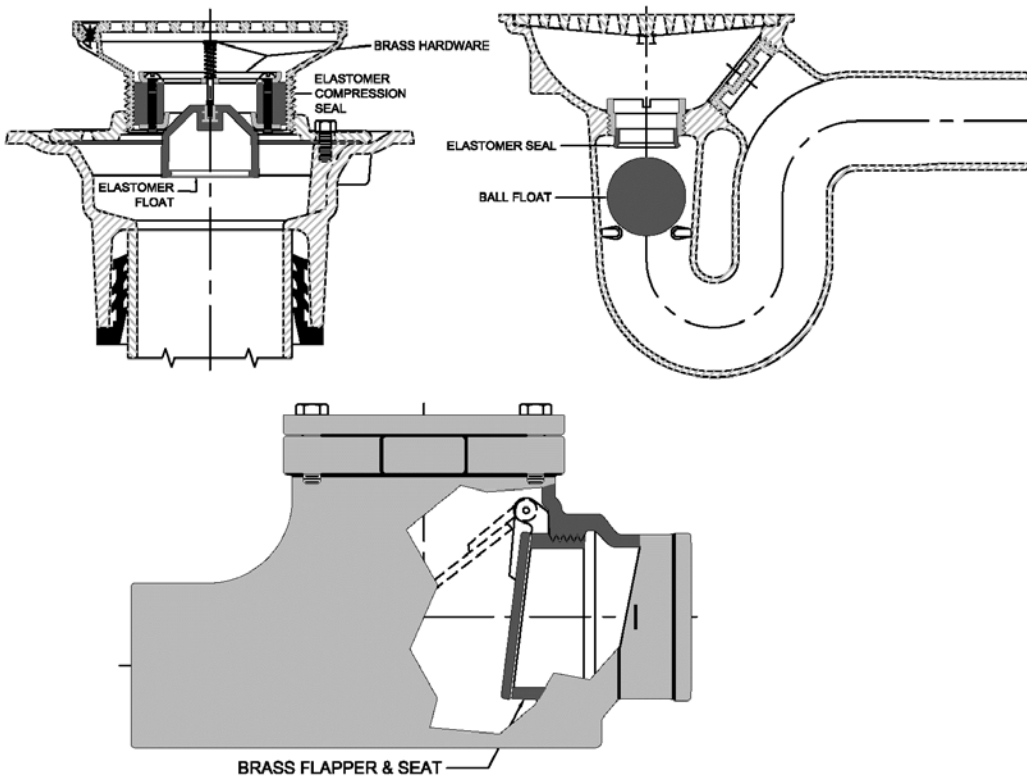

## SEWER GAS PREVENTION



Closely related to backflow protection is the prevention of sewer gas infiltration into the building. This is accomplished with traps, either integral or auxiliary to the drain. The common p-trap holds an amount of water which acts as a dam, preventing sewer gas from escaping. All areas requiring these devices may also need a trap primer and/or trap seal guard. Unless water is introduced into the trap occasionally, the existing fluid will evaporate. A trap primer valve allows small amounts of water from a domestic water supply system to trickle into the trap when a water source is activated. Most Wade drains are provided with a 1/2" NPT tapping in the side of the body to accommodate the necessary piping. The trap seal guard is a device which installs in the drain to prevent evaporation.

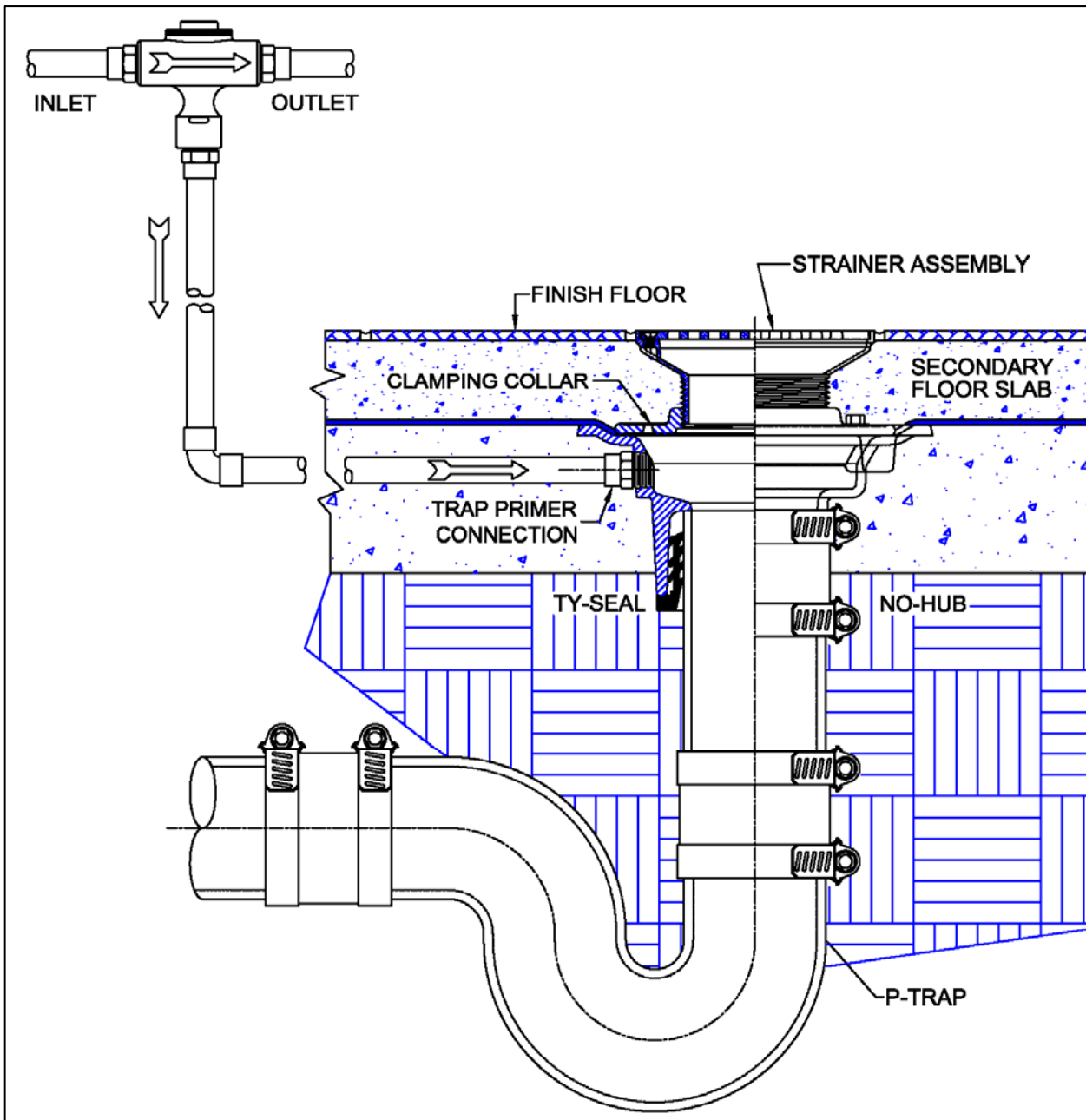



### Adjustable Tops

The Wade 1100 Series of floor drains are available with over 100 different strainer heads. Strainer heads have a 3" NPSM threaded shank which threads into a flashing collar. This type of drain is particularly adaptable to two-pour construction, such as toilet rooms, shower rooms, locker rooms and other light duty finished areas. The strainer head is easily adjusted when tile floor is being set. The reversible flashing collar in low position permits adjustment of the strainer to as low as 3/4" (measured from top of body pan to finished floor). This low position is particularly adaptable for installations where ceramic tile is applied directly to the slab. With the collar in high position, sufficient adjustment is available for all normal two-pour installations. Usually the normal sand and cement fill and ceramic tile measures approximately 1 1/2".

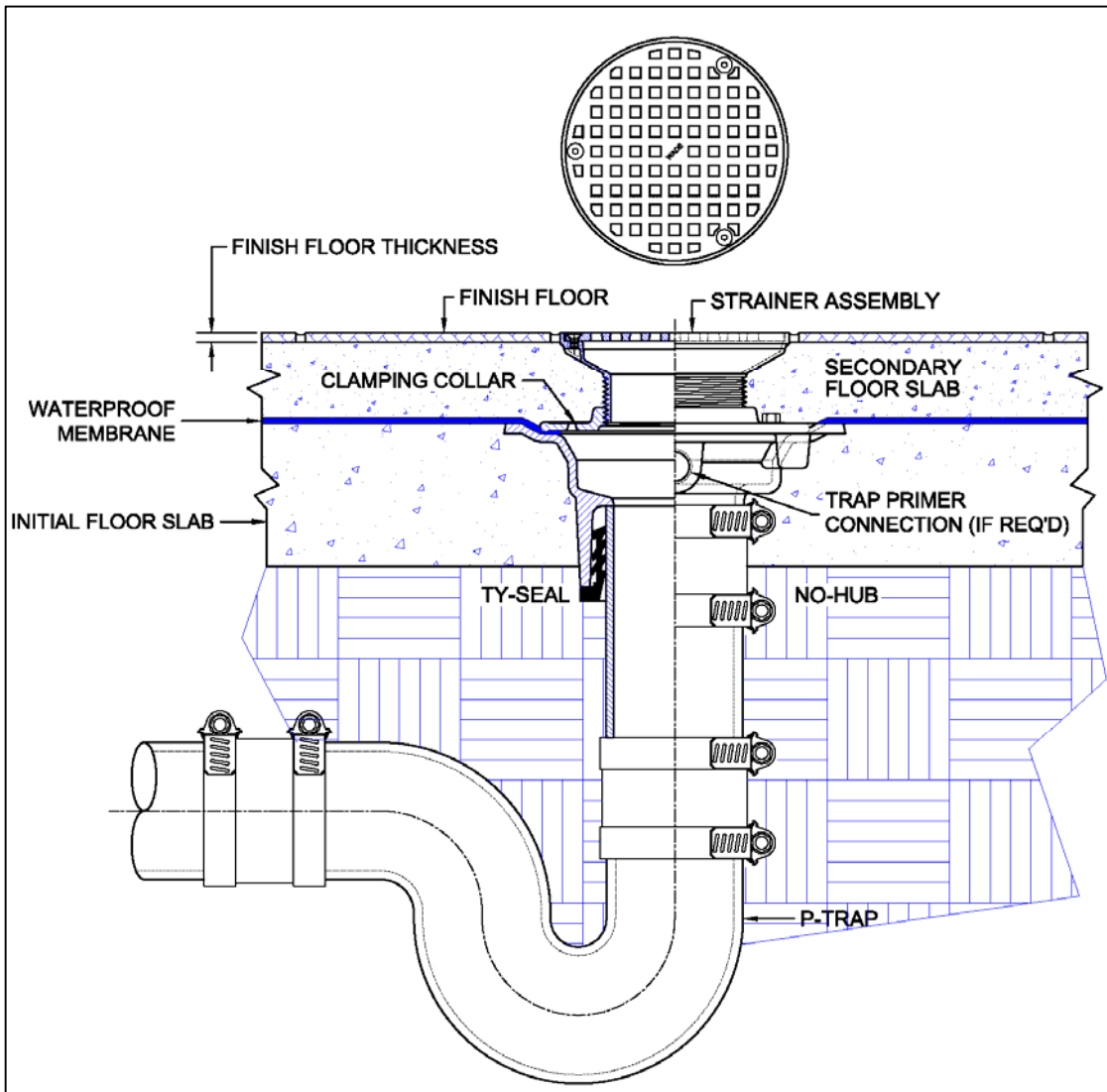

When considering Wade, also consider the experience and respectability of our parent company, Tyler Pipe and Coupling. Tyler has been an industry leader in the soil pipe market since 1935. No other company comes close to Tyler with its record of innovative products, manufacturing processes and engineering experience. With Wade and Tyler Pipe, you have a single source responsibility for the entire drainage system